

DIMENSIONS (UNIT: MM)

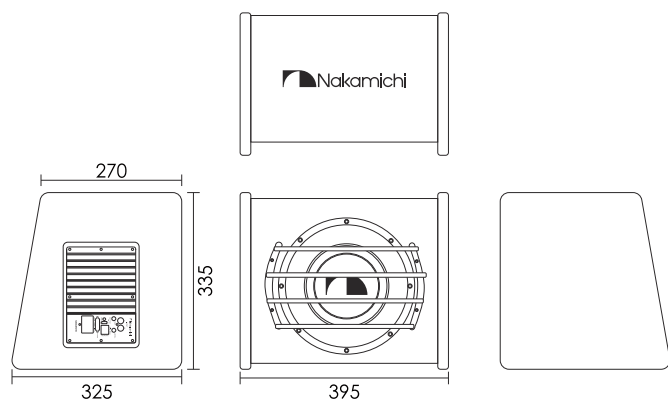

SPECIFICATIONS

Subwoofer:	10" Active Subwoofer Box
N-power:	150 Watts
MAX Power:	1000 Watts
Sensitivity(dB/W/m):	90 ± 3dB
Frequency Response:	40Hz - 160Hz
Impedance:	4 Ω
Voice Coil:	ASV Φ35.5mm
Subwoofer Magnet:	120x70x20mm, Y25
Magnet Mass:	24.9Oz (706g)
Unit Dimensions	395 x 270/325 x 335 mm
Net Mass (1pc):	Approx. 10.9kg

7 EN

YOUR SUBWOOFER BOX

Dear Customer,

Congratulations on purchasing our Nakamichi mobile system product for your sound system.

This product has been designed and manufactured to Nakamichi's exacting standards to ensure many years of audio enjoyment. For the best performance, we recommend that you have your Nakamichi product installed by an authorized Nakamichi dealer.

If you would like to install this product on your own, we recommend for you to go through this manual to familiarize yourself with all the installation requirements and procedures.

If you encounter any issues or if you have any questions on the operation of this product, please contact your nearest authorized Nakamichi dealer for assistance, or you may also contact us through our website or social media channels.

Installation of Your Product

In today's modern vehicles, it is very easy to cause damage to existing systems through improper installation. Please follow and scrutinize all wiring diagrams to ensure that you have connected everything in its proper place.

If you find yourself uncomfortable or unfamiliar with understanding the wiring and installation diagrams or testing instructions, do contact your nearest Nakamichi dealer to perform the installation for you.

Safety Warnings and Considerations

- Clean only with a dry cloth or other similar materials.
- Install your product in a dry, well-ventilated location that does not interfere with your vehicle's safety equipment.
- Do not block any ventilation openings when installing this product.
- Do not mount the product in the engine compartment of

1 EN

 Nakamichi

NBX251A User Manual



10" ACTIVE SUBWOOFER BOX



CONNECT WITH US ONLINE TO EXPLORE NAKAMICHI'S COMPLETE RANGE, INSTRUCTIONS & SOFTWARE DOWNLOADS AND WARRANTY REGISTRATION.
WWW.NAKAMICHIcaraudio.COM
Facebook: [nakamichi.global](https://www.facebook.com/nakamichi.global) Instagram: [nakamichi.caraudio](https://www.instagram.com/nakamichi.caraudio)
Made in China | 中國製造

YOUR SUBWOOFER BOX

your vehicle or in any areas of extreme heat such as mufflers, silencers, exhaust pipes or other heat producing apparatus.

- Securely mount the product so that it does not come loose in the event of a collision or as a result of repeated vibrations that might occur during normal operation.
- Installation of the apparatus must be done with great care to prevent damage to your vehicle's fuel lines, power, and other electrical wiring, hydraulic brake lines, and other systems. If possible, always visit your nearest Nakamichi dealer to perform the installation.
- Do not run any wiring outside or underneath the vehicle. Keep all wires inside the vehicle.
- Take the necessary precautions when making connections to the vehicle's battery to avoid any potential shock.
- Protect all system wires from sharp edges by carefully routing them, always use rubber grommets to protect wiring and cables whenever you are installing them through metal openings.
- Secure all wiring using cable ties or wire clamps to protect them from moving parts and sharp edges.
- This apparatus shall not be exposed to dripping or splashing, and no object filled with liquids, shall be placed on the apparatus.
- Refer all servicing to qualified service personnel. Servicing is required when the apparatus has been damaged in any way, such as the power input terminals are damaged, liquid has been spilled or objects have fallen into the apparatus, the apparatus has been exposed to rain or moisture, does not operate normally, or has been dropped.
- Fuses shall be replaced only with the correct type and fuse value, and only when the apparatus is powered off.
- Exposure to high sound pressure levels may lead to permanent hearing loss. Take every precaution to protect your hearing.
- This product is designed specifically for use with 12 volt, negative-ground electrical systems only. Using this product in systems with positive ground and/or voltages other than 12V may result in damage to the product and your system.

2 EN

TROUBLESHOOTING

If you experience operation or performance problems with this product, compare your installation with the electrical wiring diagram on the previous pages. If problems persist, read the following troubleshooting tips which may help eliminate the problems.

Products will not power up.

- Check to make sure you have a good ground connection.
- Check that the Remote Input (Turn-On) has at least 5V DC.
- Check that there is battery power on the (+) terminal (-)
- Check that there is at least 12V.
- Check all fuse, replace if necessary.
- Make sure that the Protection LED is not illuminated. If it is lit, shut off the amplifier briefly, and then repower it.

Protection LED comes on when amplifier is powered up.

- Turn down the volume control on the head unit to prevent overdriving.
- Check that there is good air circulation around the amp.

No output.

- Check that all fuses are OK.
- Check that unit is properly grounded.
- Check that the Remote Input (Turn-On) has at least 5VDC.
- Check that the RCA audio cables are plugged into the proper inputs.

Low output.

- Reset the Level Control.
- Check the Crossover Control settings.

High hiss in the sound.

- Disconnect all RCA inputs to the power sub's control panel.
- If the hiss disappears, then plug in the component driving the amplifier and unplug its inputs. If the hiss disappears at this point, go on until the faulty/ noisy component is found.
- It is best to set the amplifier's input level control as low as possible.
- The best subjective signal-to-noise ratio is achieved in this manner.
- Try to set the head unit as high as possible (without distortion).

3 EN

PANEL FUNCTION

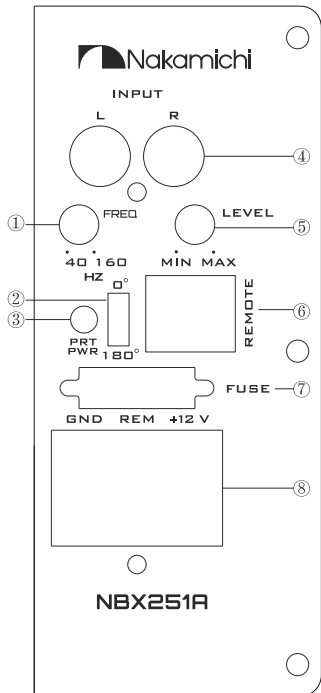

④ **Low Level Inputs** The unit accepts low level RCA inputs here.

⑤ **Volume Adjustment** Turn the volume to the minimum position before turning on. After the host is adjusted to the appropriate volume, slowly increase the volume of the active speaker until there is less distortion, then turn down the volume.

⑥ **Remote Volume Control Port** The accessory is equipped with a remote remote control with a cable. After the remote control cable is inserted into this port, the remote control potentiometer can independently control the bass volume.

⑦ **Fuse Socket** Always replace the fuse of the rating prescribed.

⑧ Power Input Terminal

- POWER(GND) must be connected to the chassis of your vehicle with a perfect electrical connection (remove some paint to reveal bare metal if necessary) and with the ground cable.
- REMOTE connect the electrical aerial output or the remote output of your radio with the remote cable.
- +12V connect the +12V power supply of car battery with the power cable. (Note: power connections).

5 EN

TROUBLESHOOTING

Squealing noise is present.

- Check for improperly grounded RCA interconnects.

Distorted sound.

- Check that the Input Level Control is set to match the signal level of the head unit.

Engine noise (static type)

- This is usually caused by poor quality RCA cables, which can pick up noise. Use only the best quality cables, and route them away from power cables.

Engine noise (alternator whine)

- Check that the RCA grounds are not shorted to the vehicle chassis.
- Check that the head unit is properly grounded.

WHAT'S IN THE BOX

Check and identify the contents of your package:

- | | |
|------------------------|-------------------------|
| 1. Subwoofer Box x 1pc | 4. Remote Cable |
| 2. User Manual x 1pc | + Remote Control x 1set |
| 3. Fuse (20A) x 1pc | |

PANEL FUNCTION

① **Low Pass Filter** You can select a cut off frequency from 40Hz to 160Hz.

② **Phase Switch** Adjust the phase from 0 to 180 degrees.

③ **POWER STATUS LED** This bi-color LED glows green when power is on and no problems are present. If one of the protection circuits comes on, it will change to red.

4 EN

INSTALLATION

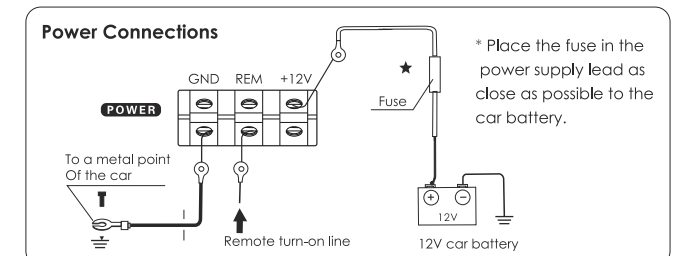
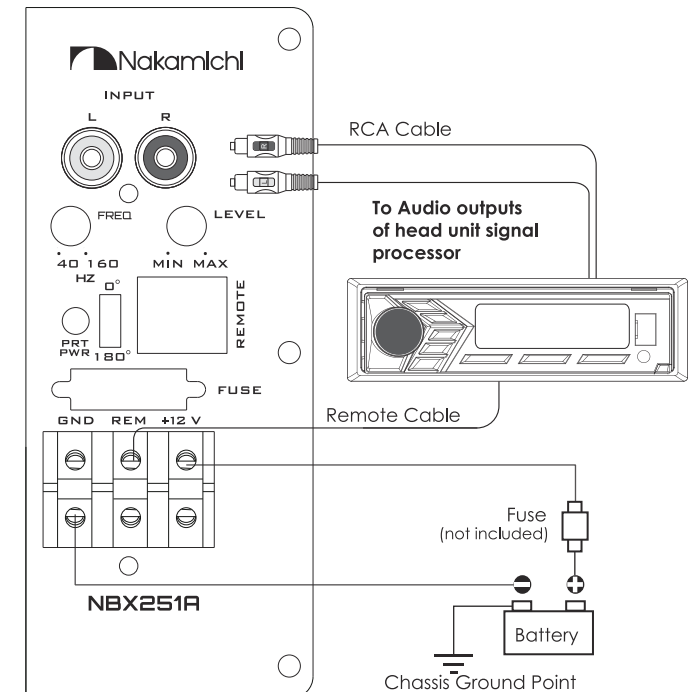

6 EN